

Data and Computer Communications

Chapter 1 – Data Communications, Data Networks, and the Internet

Eighth Edition
by William Stallings

Data Communications, Data Networks, and the Internet

- *The fundamental problem of communication is that of reproducing at one point either exactly or approximately a message selected at another point*
 - *The Mathematical Theory of Communication, Claude Shannon*

Contemporary Data Comms

- trends
 - traffic growth at a high & steady rate
 - development of new services
 - advances in technology
- significant change in requirements
 - emergence of high-speed LANs
 - corporate WAN needs
 - digital electronics

A Communications Model

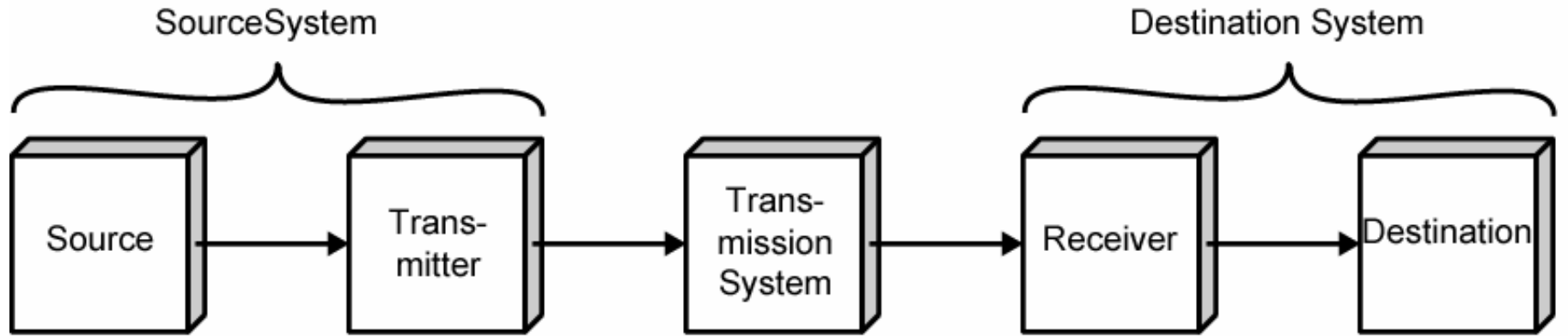

(a) General block diagram



(b) Example

Communications Tasks

| | |
|---------------------------------|--------------------|
| Transmission system utilization | Addressing |
| Interfacing | Routing |
| Signal generation | Recovery |
| Synchronization | Message formatting |
| Exchange management | Security |
| Error detection and correction | Network management |
| Flow control | |

Data Communications Model

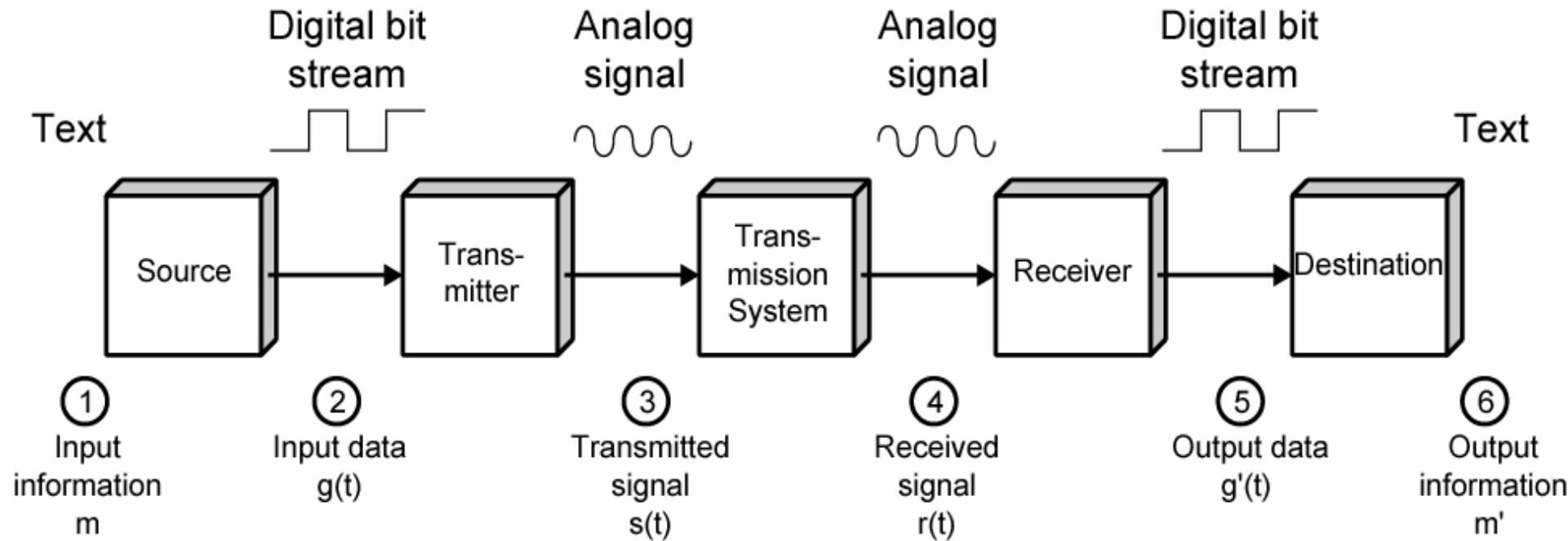

Transmission Medium

- selection is a basic choice
 - internal use entirely up to business
 - long-distance links made by carrier
- rapid technology advances change mix
 - fiber optic
 - wireless
- transmission costs still high
- hence interest in efficiency improvements

Networking

- growth of number & power of computers is driving need for interconnection
- also seeing rapid integration of voice, data, image & video technologies
- two broad categories of communications networks:
 - Local Area Network (LAN)
 - Wide Area Network (WAN)

Wide Area Networks

- span a large geographical area
- cross public rights of way
- rely in part on common carrier circuits
- alternative technologies used include:
 - circuit switching
 - packet switching
 - frame relay
 - Asynchronous Transfer Mode (ATM)

Circuit Switching

- uses a dedicated communications path established for duration of conversation
- comprising a sequence of physical links
- with a dedicated logical channel
- eg. telephone network

Packet Switching

- data sent out of sequence
- small chunks (packets) of data at a time
- packets passed from node to node between source and destination
- used for terminal to computer and computer to computer communications

Frame Relay

- packet switching systems have large overheads to compensate for errors
- modern systems are more reliable
- errors can be caught in end system
- Frame Relay provides higher speeds
- with most error control overhead removed

Asynchronous Transfer Mode

- ATM
- evolution of frame relay
- fixed packet (called cell) length
- with little overhead for error control
- anything from 10Mbps to Gbps
- constant data rate using packet switching technique with multiple virtual circuits

Local Area Networks

- smaller scope
 - Building or small campus
- usually owned by same organization as attached devices
- data rates much higher
- switched LANs, eg Ethernet
- wireless LANs

Metropolitan Area Networks

- MAN
- middle ground between LAN and WAN
- private or public network
- high speed
- large area

The Internet

- Internet evolved from ARPANET
 - first operational packet network
 - applied to tactical radio & satellite nets also
 - had a need for interoperability
 - led to standardized TCP/IP protocols

Internet Elements

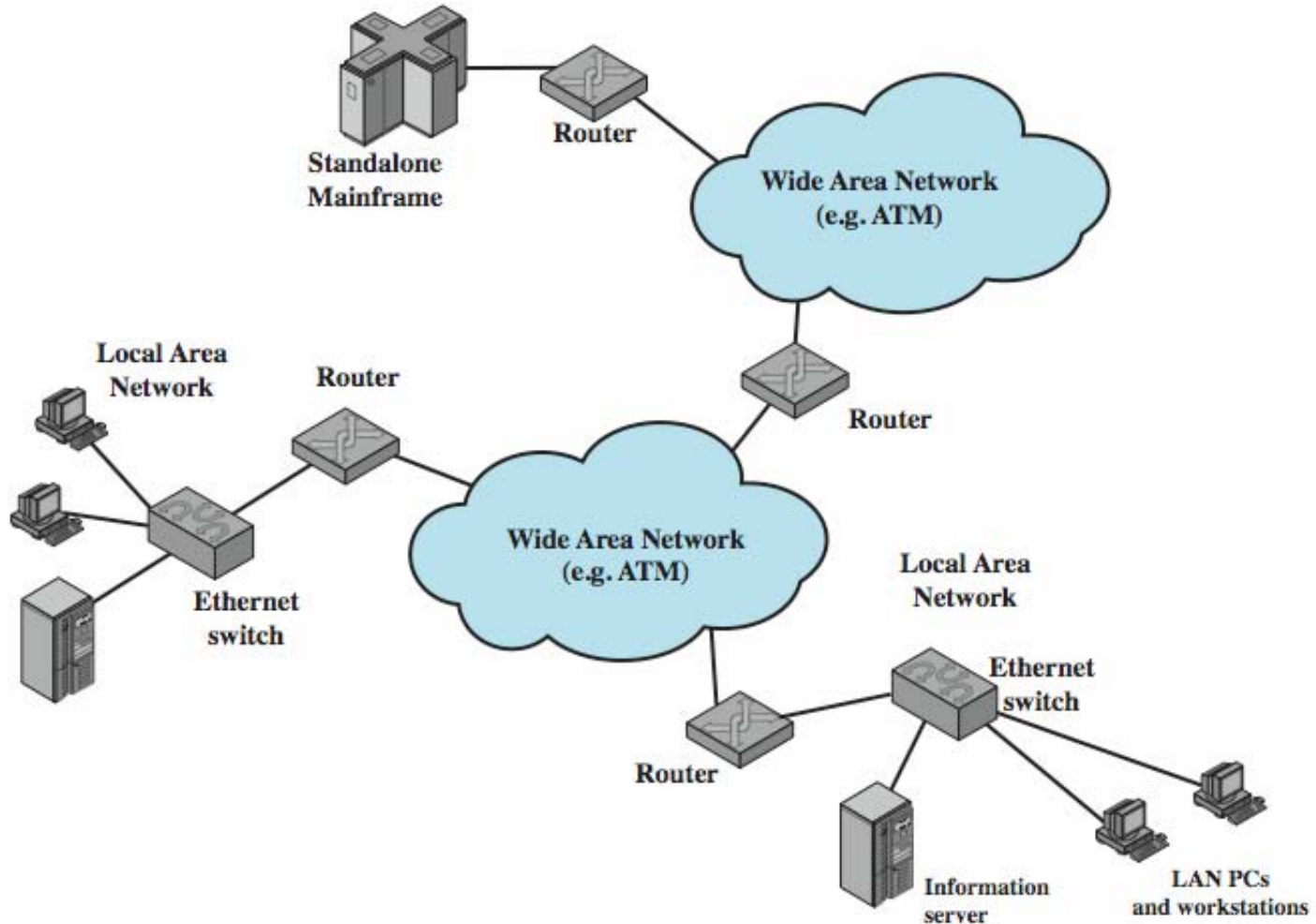

Internet Architecture

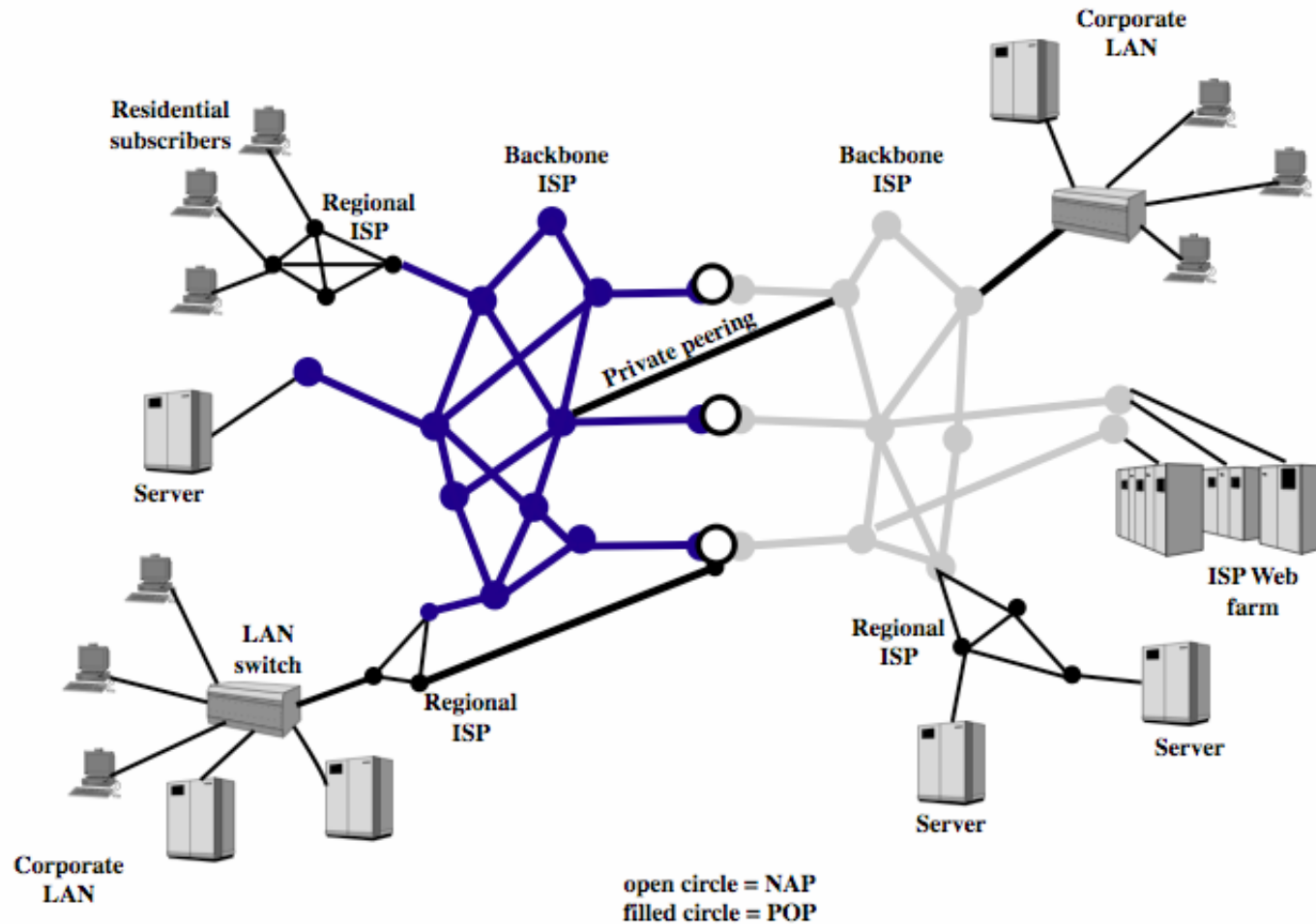

Example Configuration

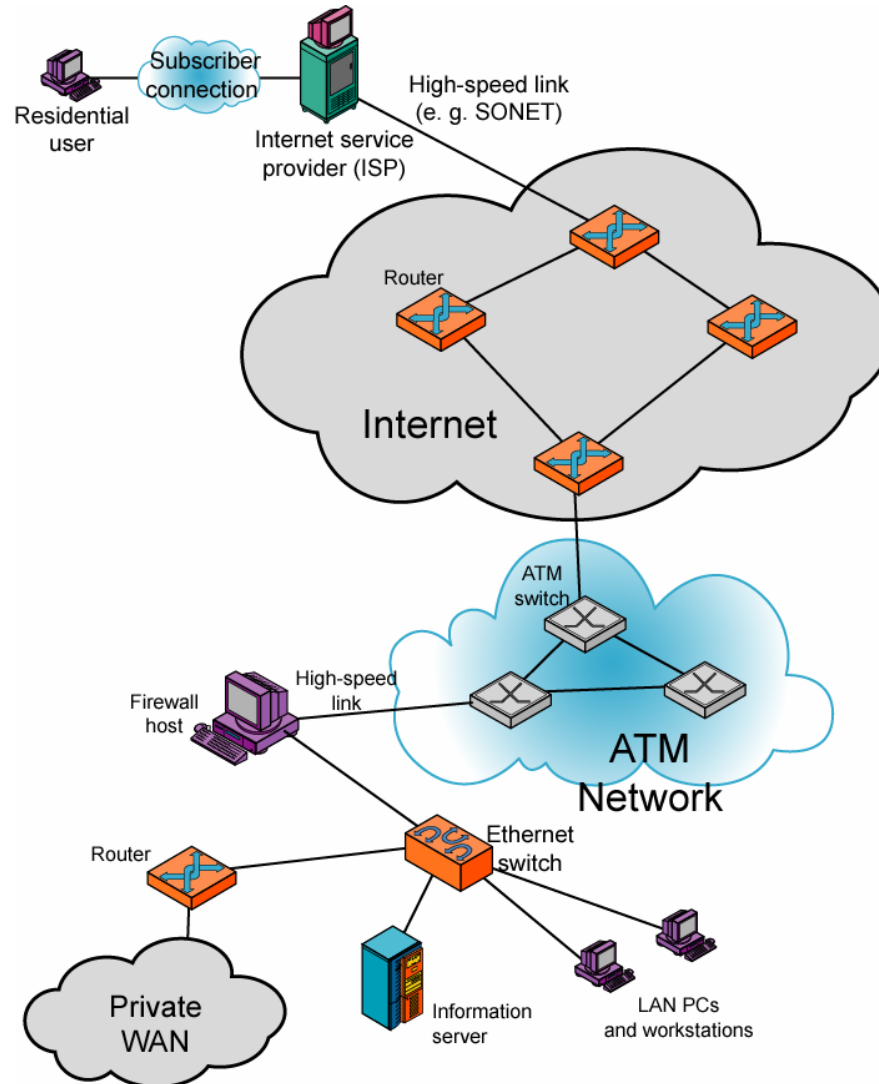

Summary

- introduced data communications needs
- communications model
- defined data communications
- overview of networks
- introduce Internet